

1) Please contact PPM or Tech Packaging for what color date code area should be.
 2) UPC codes for the USA are 80% and can be truncated no more than 50%,
 UPC codes for Canada are 85% with no truncation.

Other regions are responsible for UPC when supplying artwork.
 must meet the regions UPC requirements.
 Questions: Call the region's technical packaging representative.

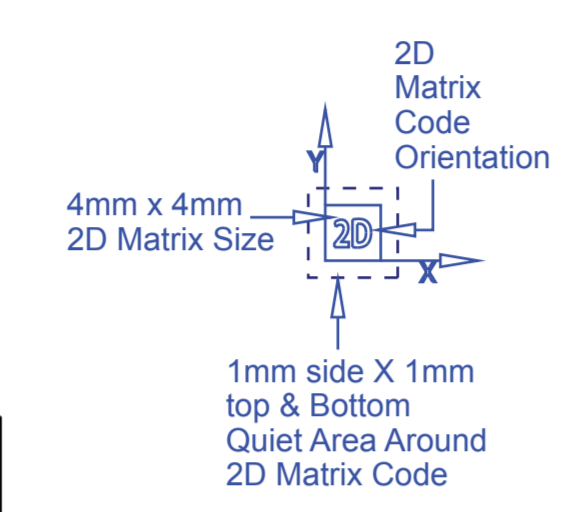

COMMENTS	2DDM AND GCAS code MUST be included in the final design	TD does NOT lock position of GCAS code; location will depend on the final design	TD DOES lock position of the 2DDM
LOCATION	2DDM FFU REQUIREMENTS		GCAS FFU REQUIREMENTS
SIZING & DETAILS	2DDM minimum size	4mm x 4mm	Font style
	Quiet zone minimum	1mm quiet area around the entire 2DDM	Font size minimum
	Total size minimum	6mm x 6mm	Font spacing minimum
	2DDM code orientation	With the X and Y axis	Font stroke minimum
COLOR	2DDM solid blocks	Must sit along the X and Y axis	Font scale
	Quiet zone minimum	1.16mm quiet area around the GCAS (allows for 1/2 character clear space [0.75mm]) and maximum color-to-color registration [0.016in=0.41mm])	Quiet zone minimum
CONTENT	- 2DDM only to contain the 8 digit GCAS/IPMS with no spaces		- GCAS to contain the 8 digit GCAS/IPMS with no spaces
CODE DATE BOX REQUIREMENTS	- LASER CODE DATE		- Code date box must be dark color over light color ink or white substrate, with varnish
	- INK JET CODE DATE		- Code date box must have no ink, no copy, and no varnish

P&G RESTRICTED

ILLUSTRATION GCAS #: MPMP-00126676

DESCRIPTION: CARTON SHAKE IT UP 3x15GRAM REFILL

INFORMATON: A-0028383

DATE: 29-NOV-2020 **SUPERSEDES: NEW**

DRAWN BY: Trident

UNITS: mm/IN **SIDE SHOWN: Outside**

ArtiosCAD Standard: PG_MASTER_TITLE_BLOCK.ARD

REVISION HISTORY:
 v .001 – Initial Construction.

LEGEND				
CUT LINE	CREASE/FOLD LINE	PERFORATION	GLUE ASSIST	PARTIAL CUT/SLIT SCORE
COPY AREA	COPY FREE	BLEED	EMBOSS/DEBOSS	COATING
Print Area TEXT / Brand Marking Ink, with Varnish or Coating	Non-Print Area No TEXT, No Brand Marking No Ink, No Varnish, No Coating	Print Area (Background Color) No TEXT / No Brand Marking Ink, with Varnish or Coating	Print Area (Background Color) No TEXT / No Brand Marking Ink, No Varnish, No Coating	Glue Pattern / Panel No Ink, No Varnish, No Coating

OUTSIDE
 GRAIN

CONFIDENTIAL PROPERTY OF PROCTER & GAMBLE
IMPORTANT: This drawing print is loaned for mutual assistance and as subject to recall at any time. Information contained herein is not to be disclosed or reproduced in any form or benefit of parties other than necessary subcontractors and suppliers without written consent of Procter & Gamble.

COPY IN CONTEXT		COUNTRIES & LANGUAGES	
P&G No: 0030494	Project No: 3000401	Project No: N/A	Date: 14/10/2021
PA Description: SHAKE IT UP MANGO COCONUT 1.5oz/3x15g RFL	Supplier: Trident Cincinnati	Supplier Ref: TR283377 C 50	
EQUIV COLORS REPRESENTATION:	Languages: English - United States		